

IN-LINE GAS BOOSTER



Description

The Solahart in-line gas booster is designed for use with either a Thermosiphon system with over temperature protection or a Streamline system. It provides all the benefits of solar hot water with the convenience and benefits of gas water heating, giving you luxurious hot water whenever you need it, all year around.

The hot water from your Solahart tank is piped to the booster. If it senses the water is up to temperature, the water passes through the gas booster without boosting and is delivered to the tap. If it senses the temperature is less than the preset level it will automatically cut in so you always have a constant stream of hot water with the lowest possible energy usage. The Solahart in-line gas booster is rated as 5-star for energy efficiency and has no pilot light, to minimise energy wastage.

Key Features

- Can be used with either Thermosiphon or Streamline systems
- 5 star efficiency for minimal energy use
- Compact design
- Natural gas and propane models available
- Optional recess box with padlock security feature available
- Optional pipe cover available

Key Benefits

- Hot water whenever you need it
- Solar savings with the benefits of gas water heating*
- Great for the environment
- Access to valuable government environmental incentives*
- Space efficient
- Reduced energy use saves on CO₂ emissions every year*
- Peace of mind with 5/3/1[†] year warranty

*Savings and incentives will vary depending upon your location, type of Solahart system installed, orientation and inclination of the solar collectors, type of water heater being replaced, hot water consumption and fuel tariff. Maximum financial savings off your hot water bill are achievable when replacing an electric water heater on continuous tariff.

[†]Warranty Details: 5/3/1, 5 year heat exchanger, 3 year labour on heat exchanger, 1 year parts including labour; applies to a single family domestic dwelling only. All other applications have a 1/1/1, 1 year heat exchanger, 1 year labour on heat exchanger, 1 year parts including labour.

Solahart In-Line Gas Booster System

The In-Line Gas Booster system is suitable for frost areas[^] but not suitable for harsh water regions. This water heater is suitable for outdoor installation only. This water heater is not suitable for use with a solar water heater without an over temperature protection system.

In-Line Gas Booster

Model		26
Part no	natural gas	PN 10143260
	propane gas	PN 10143261
Thermal input	MJ/h	199
Heating rate	L/min @ 40°C rise	16
	L/min @ 25°C rise	26
Weight	kg	21
	lbs	47
Height	m	0.647
	in	31.6
Width	m	0.350
	in	13.8
Depth	m	0.205
	in	8.1
Frost protection		standard
Gas connection		R ¾ / 20
Gas pressure maximum	kPa	3.5
	minimum - natural	kPa 1.13
	minimum - propane	kPa 2.75
Electricity supply*		240V

*A weatherproof general power outlet (GPO) is required within 1.2m of the in-line gas booster.

Accessories - Optional

Recess box (galvanised finish)	PN	299849
Pipe cover (powder coated)	PN	299848
Security Case	PN	299867
Wall mount security kit	PN	299868

In-Line Gas Booster Recess Box

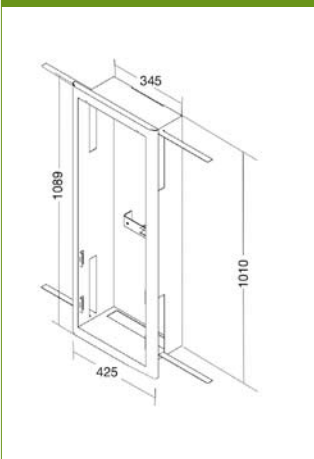

In-Line Gas Booster Pipe Cover

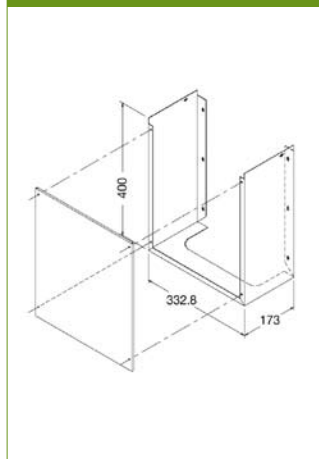

[^] Frost areas with ambient temperature down to -20°C (including wind chill factor)

Water Supply

Relief valve setting	kPa	1750	psi	255
Max. supply pressure*	kPa	800	psi	115
Min. supply pressure**	kPa	140	psi	20
Water Connections (in-line gas booster)	inlet	R ¾ / 20		
	outlet	R ¾ / 20		
Minimum flow rate	L/min	3.0		

*Maximum water supply pressure of solar preheater may be less than for inline gas booster.
**Minimum water supply pressure required to achieve the rated flow.

Power Consumption

Component	Power Consumption	Comments
Gas booster	64 Watts	Anti frost device inactive
	150 Watts	Anti frost device active

The water heater will only operate on an electricity supply with a sine wave at 50Hz. Devices generating a square wave or a lower frequency cannot be used to supply power to the water heater.

In-Line Gas Booster

