

# POWERPAK

## SOLAR WATER HEATER MODULE OWNER'S MANUAL

and

WARRANTY / INSTALLATION INFORMATION



## MODELS

5 kW and 10 kW

Solahart Industries Pty Ltd ABN 45 064 945 848

Corporate Headquarters: 112 Pilbara Street, Welshpool, Western Australia 6106  
Postal address P.O. Box 95, State Parcel Centre, Welshpool, Western Australia 6986  
Telephone International +61 8 9458 6211. Facsimile International +61 8 9458 7640

Email [solahart@solahart.com.au](mailto:solahart@solahart.com.au)  
Internet <http://www.solahart.com.au>



## CONTENTS

<b>Introduction</b>	<b>3</b>
<b>System Overview</b>	<b>5</b>
<b>Internal Component Diagram</b>	<b>5</b>
<b>Operating Instructions</b>	<b>6</b>
<b>Installation Instructions</b>	<b>7</b>
<b>Location Selection</b>	<b>7</b>
<b>Typical Array Diagram For Eight Collectors</b>	<b>8</b>
<b>Installation (Tiled Roof)</b>	<b>9</b>
<b>PowerPak Module Installation</b>	<b>10</b>
<b>Commissioning The System</b>	<b>11</b>
<b>System Operation Test</b>	<b>13</b>
<b>Technical Data</b>	<b>14</b>
<b>Powerpak Water Heater Warranty</b>	<b>15</b>
<b>Installation &amp; Warranty Report</b>	<b>17</b>



## **Introduction**

Congratulations on choosing a POWERPAK solar water heater. We are confident that your purchase will provide you many years of trouble free hot water.

Your POWERPAK solar water heater has been manufactured by a world recognised industry leader, Solahart Industries Pty Ltd.

All over the world, the Solahart name is synonymous with quality in water heating. From humble beginnings in the pioneering days of Western Australia, a reputation has been built up over nearly a century.

In 1905, two enterprising plumbers formed the company known as S. W. Hart, a name which was retained for over 70 years. Even in its early stages, S. W. Hart was involved in the manufacture of metal products for water storage and water heating. Since 1953 S. W. Hart, now Solahart Industries Pty Ltd has been producing thermosyphon solar hot water systems which is well over 40 years of hot water experience.

Solahart is the market leader in Australia and a dominant brand throughout the world. Our network of distributors covers over 70 countries including Europe, USA, Africa and Asia. In our home market of Australia we offer the widest range of thermosyphon and active solar water heater products.

We at Solahart Industries Pty Ltd are confident that your purchase of the POWERPAK water heater will provide you reliable hot water with quality, after sales service back-up.

**Thank You**



## System Overview

The Solahart POWERPAK system is designed to automatically transfer solar thermal energy collected by highly efficient Solahart collector panels into a separate (remote) potable water storage system using two independent transfer circuits.

The primary (or collector) circuit will consist of between 2 and 8 roof or frame mounted Solahart collector panels connected with insulated copper pipes to the ground-mounted POWERPAK energy transfer module. The primary circuit heat transfer fluid, which consists of potable water with a 20% mix of Hartgard (propylene glycol mix), is pumped from the POWERPAK drain back tank through the solar collectors to gather energy, then back to a heat exchanger where the collected energy is transferred to the secondary water circuit.

The secondary circuit is directly connected to a separate hot water storage system using insulated copper pipes. With the aid of a circulating pump within the POWERPAK, potable water is pumped from the storage system through the POWERPAK heat exchanger, where it gathers energy from the primary circuit, before returning the heated water to the storage system.

There are two models of POWERPAK to suit the particular installations requirement:

- (1) 10 kW suitable for connection with 4 to 8 collector panels
- (2) 5 kW suitable for connection with 2 to 4 collector panels

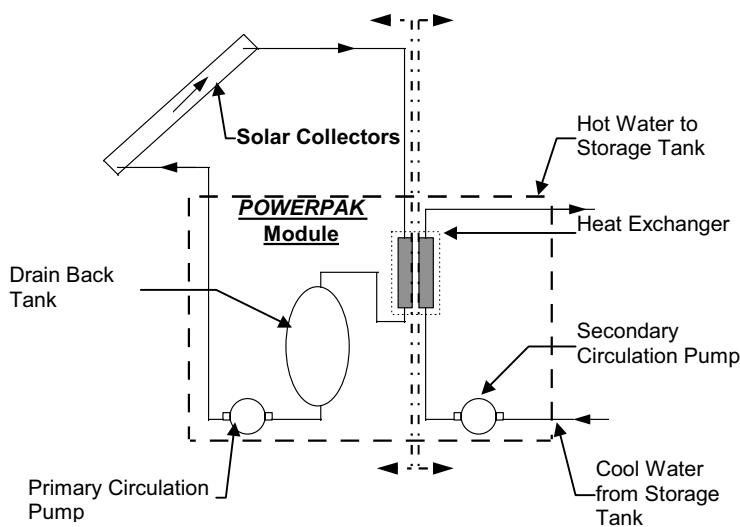

**System Schematic Diagram**

The circulation pumps are controlled using a combination of operator-selectable functions and an overriding temperature comparator system. The temperature comparator system monitors the temperature at the solar collectors and of the potable water storage system, to determine when useful energy can be collected for transfer to the potable water system. When useful energy is available and required, the circulator pumps commence circulation in both circuits. This continues until the comparator determines that there is insufficient energy being collected to justify the systems continued operation.

Using an external switch, the operator has the option to select one of three system functions: Off, Manual and Automatic.

**Drain Back Principle:** When the system is not transferring energy, the circulation pumps stop. This allows the fluid within the primary circuit to return to the drain back tank located within the POWERPAK system. This protects the fluid from the extremes of temperature in the collector array when the system is not operating.

## Internal Component Diagram

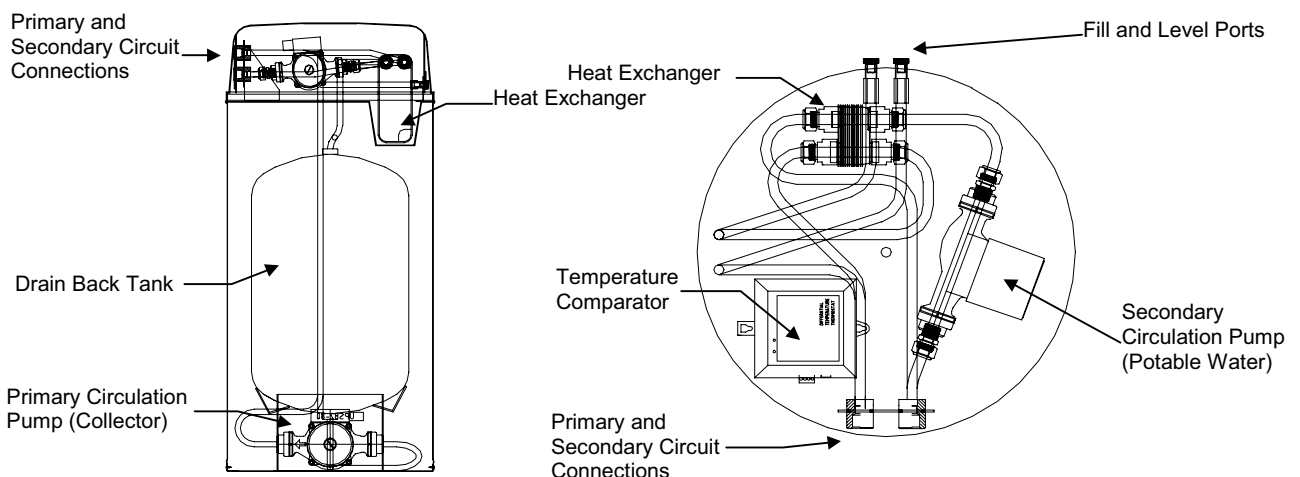

## Operating Instructions

### OPERATOR CONTROL PANEL

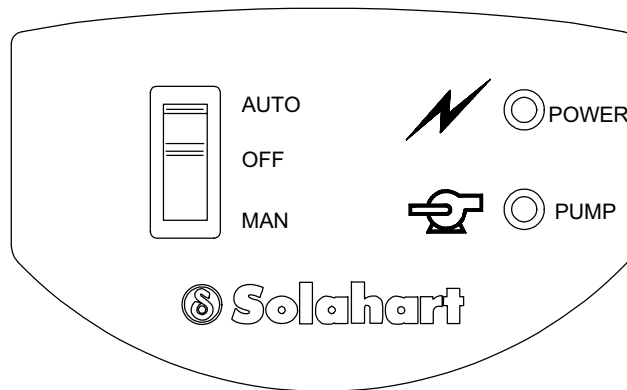

#### **AUTOMATIC (AUTO)**

When AUTOMATIC is selected, the temperature comparator located within the POWERPAK will control the circulation pump. This is the recommended setting for the POWERPAK when in normal operation. The Power light will be ON, and the circulation pump running light will be ON when the pump is running as determined by the temperature comparator.

#### **OFF**

When OFF is selected the circulation pump and temperature comparator will not operate. The Power light will be OFF indicating that the control system is switched off.

#### **MANUAL (MAN)**

When MANUAL is selected the circulation pump will operate continuously. The serviceman normally uses this selection for system testing and commissioning purposes. The Power light will be OFF and the circulation pump running light will be ON.

#### ***Recommended Operating Mode***

To maximise the energy savings from your POWERPAK, it is recommended that the **AUTO** setting is selected.

#### **CLOSED CIRCUIT FLUID LEVEL - FAULT INDICATOR**

This indicator will illuminate when the closed circuit fluid level falls below 15% of the drain back tank volume. When illuminated both circulating pumps will be prevented from operating. Illumination of the fault light indicates a problem with the system; call a Solahart technician to examine the installation.

If the fault light comes on, the following steps must be taken:

1. the reason for the fluid loss must be determined and rectified,
2. the closed circuit refilled with the specified water and Hartgard fluid mix, and
3. the power connection reset by switching the mains OFF and then ON again.

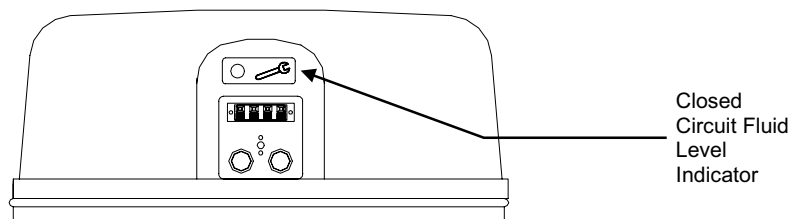

**CLOSED CIRCUIT FLUID LEVEL - FAULT INDICATOR  
LOCATION**

**SAFETY**

This appliance is not intended for use by young children or infirm persons without supervision.  
Young children should be supervised to ensure that they do not play with the appliance.

**Installation Instructions****GENERAL**

Installation of this water heater must be performed by an Authorised Person and in accordance with Local Authority Safety regulations, and Electrical and Plumbing Codes applicable in your area. In Australia, for example, the installation must comply to Australian Standard (AS 3500.4) "National Plumbing and Drainage Code, Part 4: Hot Water Supply Systems".

**Important**

Additional information on installing the pipe work to and from the POWERPAK can be found in Solahart Technical Bulletin #136. This can be obtained from your Solahart dealer or from Solahart directly.

**Location Selection****Collector Panels**

For optimum performance the collector panels should be installed to face the equator (South in the Northern Hemisphere, North in the Southern Hemisphere) **ALWAYS USE A COMPASS TO CHECK ORIENTATION**. Deviation from the equator up to 45° East or West has little effect on total annual solar contribution (approximately 4 per cent). Should it not be possible to face the equator the decision of either EASTERLY or WESTERLY direction must be made.

(a) If major hot water draw is before 2 p.m. favour EASTERLY

(b) If major hot water draws after 2 p.m. favour WESTERLY.

The westerly direction is more commonly used.

The collector panels should be installed on a roof of pitch or angle that is the same as the latitude angle of the site. Roof angles within 20° of the latitude angle will have little effect on the total annual solar contribution (4%). Minimum roof angle is 10° for with-pitch installations.

If it is necessary to face the collector panels 45° East or West of the equator then a flatter (lower pitch) installation will give better performance. Additional panels facing east or west may be more aesthetically, economically and thermally beneficial than mounting the Collector Panels on roof brackets to face the equator.

The collector panels must be installed in an area that is free of shade all year round. Check high trees and other obstacles for winter shade.

The collector panel location should not be more than 7 metres vertically, for a 10kW POWERPAK, and 5.5 metres, for a 5kW unit, above the base of the POWERPAK with a maximum pipe run of 16 metres from the POWERPAK. For installations with greater distance than these please consult Solahart for revised pump sizes and configurations.

**POWERPAK Module**

Select a suitable location near the hot water storage system to which the POWERPAK is to be connected. As the POWERPAK is weatherproof, the location may be internal or external. However, in cold climates an internal location is preferred.

The POWERPAK must be positioned such that the electrical socket is accessible.

To minimise heat losses the POWERPAK should be located as close as possible to the hot water storage system and at the same level.

### Typical Array Diagram For Eight Collectors

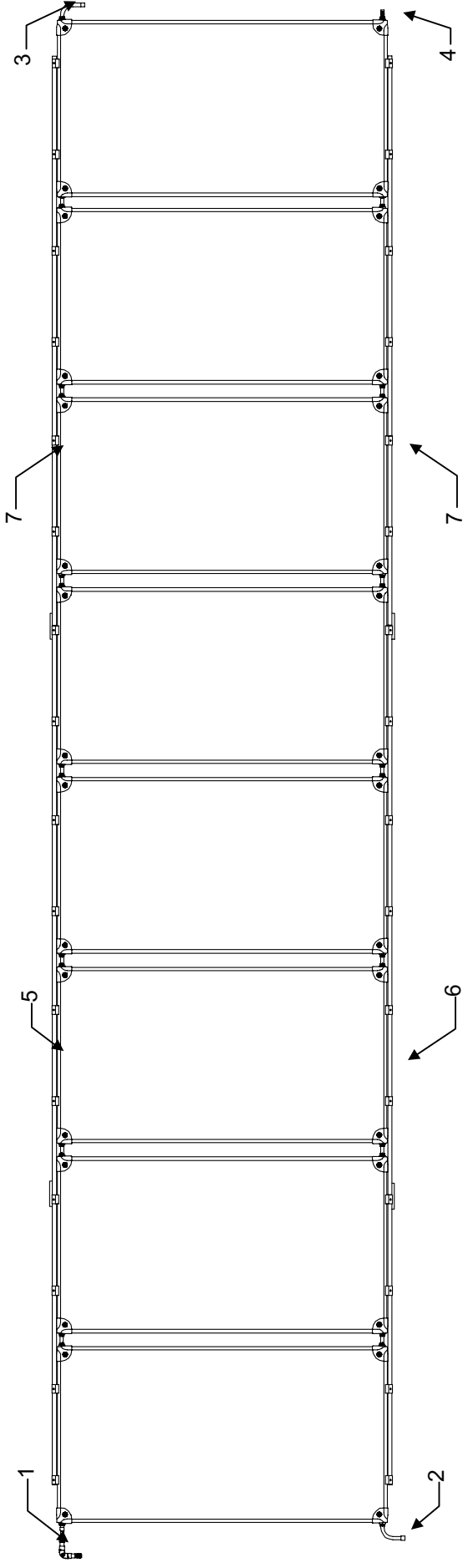

- 1 Temperature Sensor
- 2 Collector flow connection
- 3 Collector return connection
- 4 Expansion Valve connection
- 5 Top collector rail
- 6 Bottom collector rail
- 7 Collector clamps

**NOTE: The POWERPAK System is suitable for installation with between 2 and 8 collectors.**

## Installation (Tiled Roof)

Select a suitable area of roof on which to install the collectors. Ensure that the area is even and without cracked or damaged tiles.

Locate the upper most position of the collector array on the roof area, be sure that there is at least 2 tiles between the ridge cap and the collector top so that the array can be installed without damage to the capping. From the selected top position measure 1940 mm down from this point to determine the location of the collector rail. Mark this location. Remove several roofing tiles from this location to expose the rafters. Hook the stainless steel straps (Part No. 33-0847) to the rail and line up the straps with the rafters. Ensure that they are not more than 1.6 m apart and not closer than 1 m. The collector rails should be joined by means of the drive cleats supplied in the parts kit. After positioning the rails level, raise the right hand side 10 to 20 mm and fix the straps to the rafters using suitable bolts. Replace the tiles.

Now using a lifting device lift collectors onto the roof and place the collectors carefully into the collector rail. Remove red transit plugs from each collector.

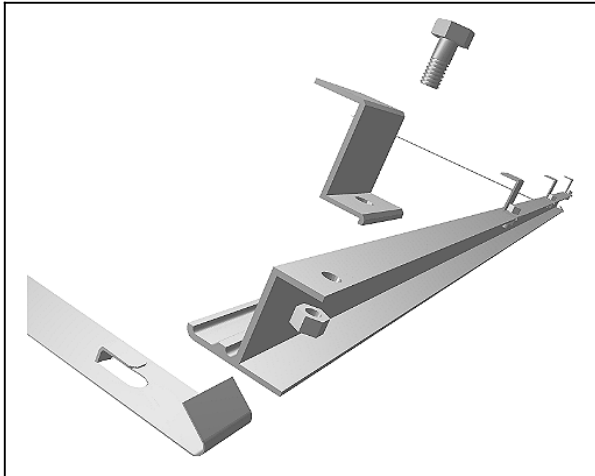

Care should be taken to ensure that the hot outlet side of the collector array is slightly higher than the inlet side (10 to 20 mm) to exclude the possibility of air bubbles in the top of the collector array.

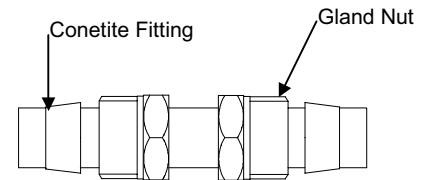

**Collector Union**

Fit the collector unions between the collectors taking care to correctly locate the cones and nuts correctly into the collector fittings. Do not over tighten the connections as permanent cone damage may occur.

Locate the top rails, with fixing straps attached snugly, onto the collectors. Remove tiles, as required, from above the rail to expose rafters then screw fix the straps to the rafters in this position. Replace the tiles after this operation is completed. Fit the collector clamps to both rails (4 per collector) with the nuts and bolts supplied to the pre drilled holes in the collector rails.

### Temperature Sensor

The "temperature sensor" should be fitted to the top of the left hand collector fitting directly above the collector flow line inlet position. Refer to the Collector Installation Diagram.

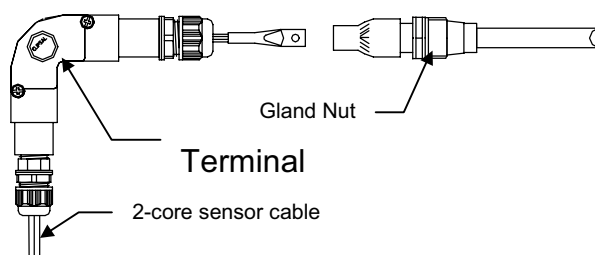

The assembly is fixed to the collector socket using a standard gland nut and cone fitting assembly. Check that the sensor is pushed fully into the housing tube within the collector header.

Pass the 2-core sensor cable through the cable entry gland and connect to the terminal block within the housing assembly.

### Expansion Control Valve

The "expansion control valve" consists of a Solahart PR6 valve, Conetite adaptor block and gland nut. This assembly should be fitted to the bottom of the right hand collector fitting directly below the collector return line outlet position. Refer to the Collector Installation Diagram. If necessary a drain line can be fitted to this fitting to channel any expansion away from roof guttering, rain water tanks etc.

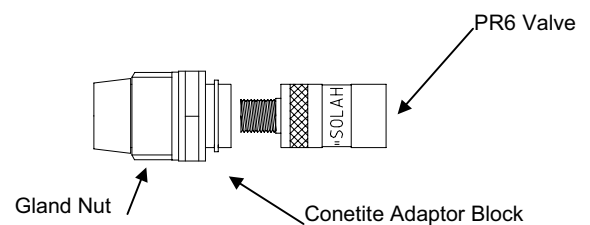

**Note: Discharge only occurs during the first heating cycle or until the maximum operating temperature is achieved.**

**Collector Return Line Connection**

Final connection is achieved by welding (where solder is permitted, the melting temperature must be greater than 220°C) a “remote connection pipe” to the insulated copper pipe returning to the POWERPAK system. The remote connection pipe is then inserted into the top collector fitting of the right hand collector. The connector is secured to the collector fitting using a standard gland nut supplied with the connector. Refer to the Collector Installation Diagram

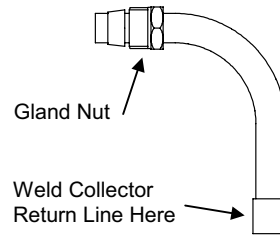

**Collector Flow Line Connection**

Final connection is achieved by welding (where solder is permitted, the melting temperature must be greater than 220°C) a “remote connection pipe” to the insulated copper pipe rising from the POWERPAK system. The remote connection pipe is then inserted into the bottom collector fitting of the left hand collector. The connector is secured to the collector fitting using a standard gland nut supplied with the connector. Refer to the Collector Installation Diagram

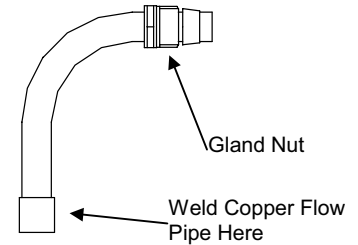

**Collector To POWERPAK Connections  
Pipework**

Insulated copper DN15 (or nearest local equivalent) flow and return lines must be installed from the collector array to the POWERPAK location. **During installation it is very important to install a constant fall of at least 5° back to the POWERPAK on both flow and return lines.** If these lines are taken through the roof material, suitable flashing procedures in line with local approval practice should be employed.

**Collector Temperature Sensor Lead**

Install a 2 core, 0.75 mm<sup>2</sup> Figure 8 cable between the temperature sensor in the collector array and the POWERPAK.

**PowerPak Module Installation**

**Collector (Primary) Circuit Connection**

The flow and return lines from the collector array are connected to brass conetite sockets located on the top left side of the POWERPAK as shown.

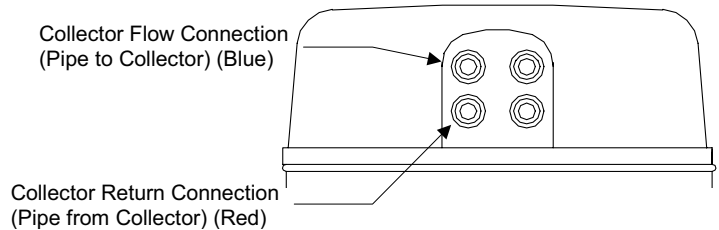

**POWERPAK To Storage Hot Water System Inter Connection  
Pipework**

Install two insulated DN15 copper flow and return lines from the POWERPAK to the storage hot water system.

Important: If the water quality is poor or the mineral content high, a filter and/or water conditioner must be installed on potable water line to the PowerPAK.

To minimise heat losses the POWERPAK should be located as close as possible to the hot water storage system.

The location of the connections to the hot water storage system must be determined by the supplier of the storage system. Any water storage tank connected to the potable water connections on the POWERPAK must be protected with the appropriate valves and safety devices with a maximum setting of 1000kPa and 99°C.

### Storage Tank Sensor Lead

Install a 2 core, 0.75 mm<sup>2</sup> Figure 8 cable between the POWERPAK location and the temperature Sensor in the hot water storage system. The temperature sensor is supplied with the POWERPAK and a suitable location at the base of the storage system should be determined with the system supplier.

The storage tank sensor should be placed at the lower part of the storage tank between the cold and hot connection to the POWERPAK. Never place the sensor lower than the cold pipe connection of the storage tank to the POWERPAK. A sensor position too low can cause the pump to run into the evening or overheating the POWERPAK system. A position too high can stop the pump before the maximum volume of water in the storage system is heated. Ensure that the sensor makes a good thermal contact with the tank.

### Hot Water (Secondary) Circuit Connection

The hot water flow and return lines from the hot water storage system are connected with DN 15 (1/2") brass gland fittings to brass sockets located on the top right side of the POWERPAK as shown in the adjacent diagram.

### Temperature Sensor Connections

Connect the sensor leads from the collector array and the hot water storage system to the terminals located on the top right hand side of the POWERPAK as shown in the adjacent diagram.

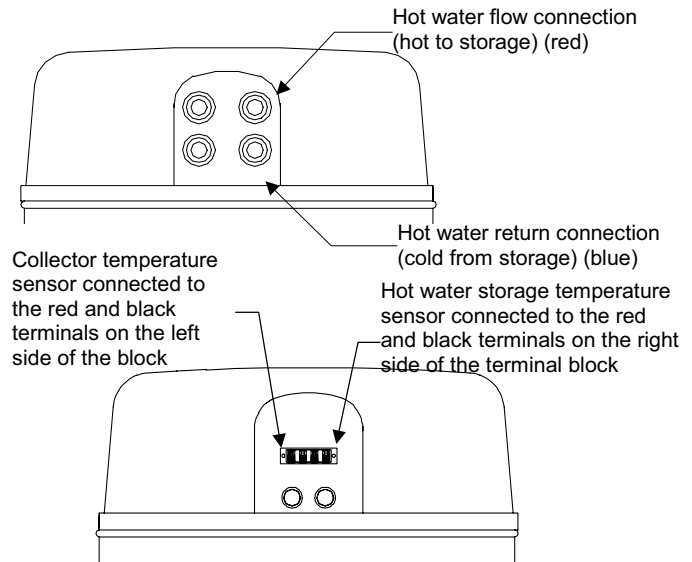

### Electrical Supply

The POWERPAK is supplied with an electrical plug and cord system, which is fitted with a standard domestic power plug and can be plugged into a domestic power outlet located adjacent the POWERPAK. The POWERPAK must be positioned such that the power plug is accessible. Where the POWERPAK is installed external to the building, weatherproof fittings must be used.

If the power cord is damaged, it must be replaced by the manufacture, its service agent or a similarly qualified person in order to avoid a hazard.

The maximum current draw from the electrical supply is 3 amps at 240 volts, 50 Hertz.

## Commissioning The System

### Pre Commissioning Check

Before starting the commissioning process check the following actions have been completed:

1. Potable water system is full and pressurised ready for heating. **Do not start the commissioning procedure until this step has been completed. Failure to check may cause irreparable damage to the system.**
2. Collector temperature sensor connected
3. Expansion valve assembly fitted to collector array
4. Collector flow and return line connections completed to collector array
5. Collector array rises gently to the right or hot return side connection on the collector array
6. All pipe work has a gentle and continuous fall from the collector array to the POWERPAK module
7. Collector circuit connections are connected at the POWERPAK module
8. Hot water circuit connections are connected at the POWERPAK module
9. Sensor lead connections (Collector & Storage) are connected at the POWERPAK module
10. Final connection of the hot water pipe work at the storage system end is completed.

### Filling the Drain Back Tank

1. Remove both the **Fill and Level Plugs** (located under the cover for temperature sensor connections at the side of the unit) and insert the two **Charging Adaptors**.

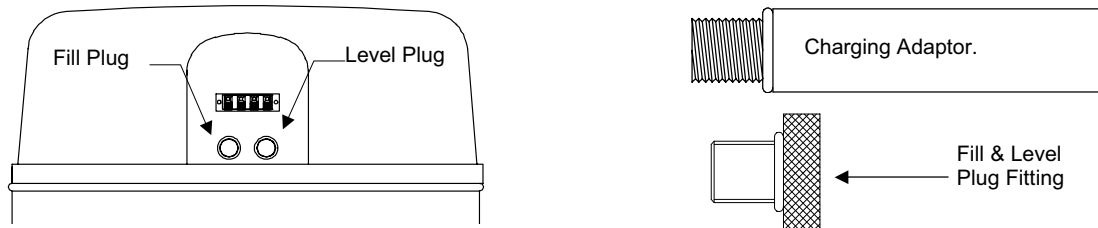

2. Secure a piece of clear hose to each of the adaptors and secure using hose clamps.
3. Place the loose end of the level hose into a bucket or similar to collect overflow from the charging process.
4. Syphon potable water through the fill hose into the system until water flows from the level fitting hose. (Approx 28 litres for 5 kW POWERPAK and 55 litres for 10 kW POWERPAK)
5. Remove both hoses from the connection ports.

### Emptying the Drain Back Tank (Service Procedure only)

1. Turn OFF electrical and water supplies to the module and allow 5 minutes for the closed circuit fluid to return to the drain back tank.
2. Remove the **Fill Plug** to release any pressure in the system then replace plug into socket.
3. Secure a piece of clear hose to the drain fitting located adjacent the Collector Circulation pump and place into a container of sufficient volume to hold the collector circuit fluid.
4. Remove the Fill Plug which will allow the fluid to flow from the Drain Back Tank into the container.

Do not turn ON the electrical or water supplies until the drain back tank has been refilled.

### Pressure Testing the System

**CAUTION: When testing please ensure the collectors remain covered with their cardboard protectors until the testing is completed.**

1. Remove the PR6 valve from the expansion control fitting at the lower right corner of the collector array and insert in its place the plug removed from the level fitting on the POWERPAK module.
2. Re-insert the fill plug removed during the filling process to the module.
3. Insert the test block assembly into the level port at the module.
4. Attach the air pump to the connection valve and pump the system pressure up to 120 kPa on the gauge.
5. Disconnect the air pump and check the valve for leakage then note the pressure gauge reading.
6. Allow the system to stand under pressure for at least 10 minutes then re-check the gauge to confirm that no pressure change has occurred.
7. If the pressure is constant, go to step 9.
8. If a leak has been detected, then locate and repair it before operating the system. The simplest method to detect a leak in the closed circuit is to spray a soap-and-water solution on each joint and connection in the pipe work. Bubbles will indicate a pressure leak. Repair the leak and return to step 4 for a system re-test.
9. Release the air pressure from the system by depressing the centre pin of the air pump connection in the test block.
10. Once all the air pressure has been released, remove the test block from the level port.
11. At the collector array, remove the plug from the expansion control fitting and re-fit the PR6 valve in its place.
12. Syphon Hartgard into the system as described in the paragraph "Filling The Drain Back Tank". (1 x 4.5 litres for 5 kW POWERPAK or 2 x 4.5 litre for 10 kW). During this operation water will flow from the level port into the catchment bucket.
13. Remove the hose connections and re-fit the plugs to the fill and level ports.

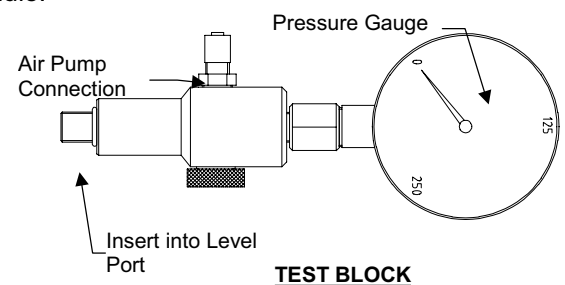

## System Operation Test

**CAUTION: Do not operate the system until Hartgard has been added to the collector circuit**

The following functional checks should now be conducted.

1. Switch the system to **MANUAL** and check that the pump/s are running.
2. Switch the system to **AUTO**.
3. If the collector temperature is more than 9°C above the storage tank temperature then the circulation pumps will run.

To check that the controller is operating correctly, the storage tank sensor temperature must be raised above the collector temperature to stop the pumps.

**Note:** This can be achieved by immersing the storage tank sensor into a small container of boiling water. Within 1 minute the pumps should stop.

**Note:** If the pumps do not stop, then the sensors and sensor circuits must be checked in accordance with the procedure detailed in the section **Sensor Operational Test**.

4. If the temperature difference between the collector and storage tank is less than 5°C the pumps will not run.

To check that the controller is operating correctly, the collector sensor temperature must be raised above the storage tank temperature to start the pumps.

**Note:** This can be achieved by immersing the collector sensor into a small container of boiling water. Within 1 minute the pumps should start.

**Note:** If the pumps do not start, then the sensors and sensor circuits must be checked in accordance with the procedure detailed in the section **Sensor Operational Test**.

5. Switch the system to **OFF**. The pumps should now stop and all of indicators should turn off.
6. The system is now fully functional and should be left in the AUTO mode for permanent operation.

### **SOLAR CONTROLLER SELF-DIAGNOSTICS**

If the solar controller detects a problem with the sensors, it will automatically turn off the pumps and the red power LED will start to flash.

- 3 flashes - a short in the collector sensor or lead
- 4 flashes - a break in the collector sensor or lead
- 5 flashes - a short in the tank sensor or lead
- 6 flashes - a break in the tank sensor or lead.

This fault must be repaired (See **Sensor Operational Test** below) and the unit switched OFF then ON again, to reset it before the POWERPAK will operate.

### **SENSOR OPERATIONAL TEST**

**This test is only required if a problem is located with the automatic operation of the controller when tested as detailed above. This is not required under normal circumstances.**

To perform the sensor check you will require a **multimeter** set to the resistance or ohm setting to perform resistance measurements.

1. Disconnect the sensor cables from the terminal block located on the side of the system
2. Connect the multimeter leads across the sensor cables and note the multimeter reading.

If the multimeter shows an open circuit (or break in the cable or bad connections at the sensor), then the cable to the sensor should be checked for possible damage. This would normally be found around sharp edges such as roof flashing etc.

If the multimeter shows a short circuit, then the cable to the sensor should be checked for possible damage. This would normally be found around sharp edges such as roof flashing etc or a nail or staple through the cable.

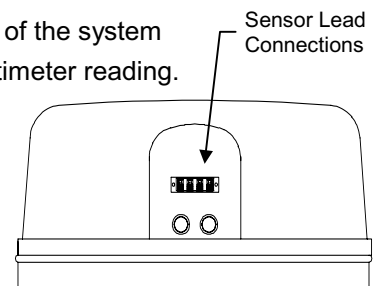

If the cabling is correct the multimeter should indicate a resistance reading which reflects the temperature at the sensor location as shown on the table below:

°F	°C	Ohms Resistance	°F	°C	(Approx) Ohms Resistance
41	5	25380	122	50	3600
50	10	19890	140	60	2490
59	15	15710	149	65	2090
68	20	12490	158	70	1750
77	25	10000	176	80	1250
86	30	8057	194	90	920
104	40	5326	212	100	680

## Technical Data

### Dimension Detail

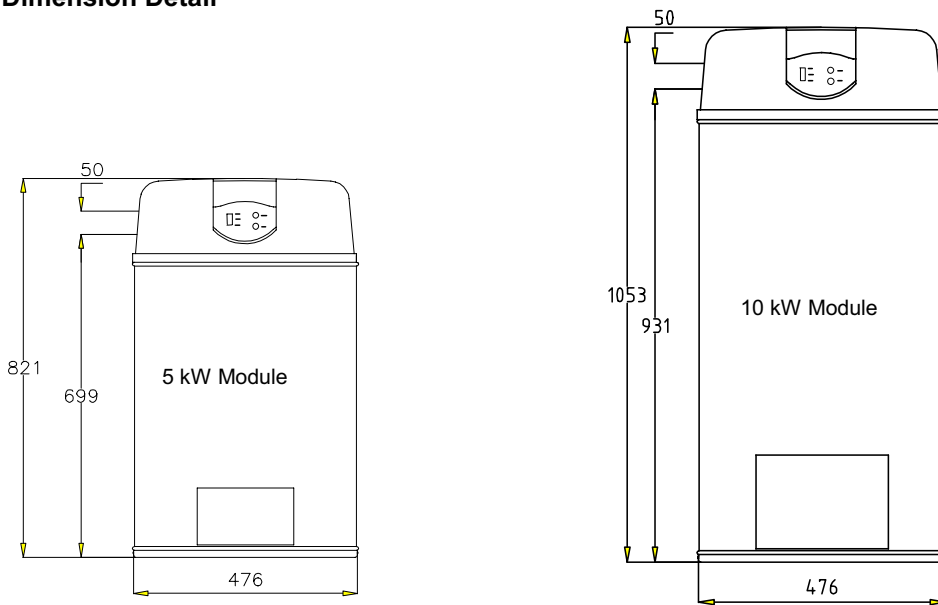

### Solahart Collector Panel Details

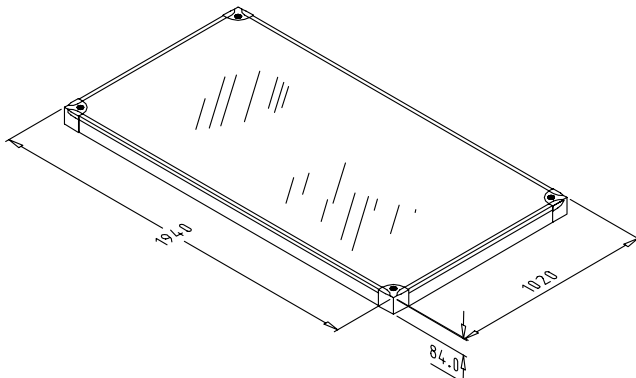

### Collector Panel Data

- Selective Surface
- Absorptivity = 0.93 (± 0.05)
- Emittance = 0.12 (± 0.02)
- Glass = Low Iron with 94% transmittance

## **Powerpak Water Heater Warranty**

(Worldwide)

POWERPAK water heaters are produced by Solahart Industries Pty Ltd (the manufacturer) who provide the following manufacturer's warranty.

The protection offered by this warranty is in addition to all other non excludable rights and remedies that the consumer has under the Trade Practices Act (in Australia) and similar country, state or territorial laws as they may apply.

The manufacturer warrants the POWERPAK water heater against manufacturing defects, faulty material and/or workmanship and leakage from corrosion upon the following terms:

**5 years on the tank, internal pipe work and collectors**

Note: Collector glass in not included

3 years on labour

12 months on all components.

### **Conditions**

1. The above is subject to an area within a 30 kilometre radius of the Solahart dealer from whom the unit was purchased. Customers outside this area will be subject to freight and travelling charges incurred by the Solahart dealer conducting the work.
2. Warranty claims must be submitted to the Solahart dealer from whom the water heater was purchased within one month of the component failure.
3. A call out fee applies to warranty calls made outside normal Solahart business hours.

### **Exclusions**

1. The manufacturer shall carry no obligation under this warranty in the case of accident, Acts of God, installation/repairs carried out by persons outside Solahart installation and maintenance instructions.
2. The warranty applies only to the components supplied by the manufacturer and does not include plumbing or electrical components supplied by the installation contractor.
3. No responsibility is accepted for any consequential loss or damage caused by a defect.
4. No warranty applies to damage to the heat exchanger or system caused by poor water quality or high mineral content.



# PowerPak

## Installation & Warranty Report

Dear Customer,

To register your warranty please ensure the following information is correct then sign and return to our Solahart Industries Pty Ltd freepost address:

Solahart Industries Pty Ltd.  
 Reply Paid Perth 354,  
 Welshpool.  
 Western Australia 6106

**WARRANTY:** For details and conditions of warranty see the warranty section of this manual

Please complete all details below

<b>Purchaser's Name</b>			
<b>Installation Address</b>			
<b>Suburb</b>			
<b>State</b>		<b>Postcode</b>	
<b>Telephone</b>		<b>H)</b>	<b>W)</b>
<b>Solahart Dealership</b>		<b>Consultant</b>	

### Important Details

<b>Installation Date</b>			
<b>Model - type</b>			
<b>Type of Installation (Please circle)</b>		<b>New</b>	<b>Existing</b>
<b>Work Delivery Details</b>			
<b>POWERPAK Serial No</b>			
<b>Collector Serial No's</b>		<b>1)</b>	<b>2)</b>
		<b>4)</b>	<b>5)</b>
		<b>7)</b>	<b>8)</b>
<b>Service's Due</b>			
<b>Installers Name</b>			
<b>Comments</b>			

<b>Date:</b> .....		
<b>Signature:</b>		<b>Customer</b>
<b>Installer</b>		

White Copy: Head Office

Yellow Copy: Dealer

Blue Copy: Sales Office

Green Copy: Manual

949100